

Table of Contents for Composting and Grasscycling

Introduction.....	1
Grasscycling.....	2
Outdoor Composting.....	3-4
Building Your Own Compost Bins.....	5-6
Indoor Composting	7-8
Using Your Finished Compost.....	9
Anoka County Compost Sites.....	10
Resources and References.....	Back Cover

Introduction

Minnesota law prohibits mixing yard waste with your garbage. Composting and grasscycling are two ways that you can use these valuable natural resources to improve your yard while reducing waste. This guide describes the benefits of composting and grasscycling, and provides all the information you need to get started. Other resources that you may find helpful are listed on the back cover.

Grasscycling = grass recycling

Leaving your grass clippings on the lawn is called “grasscycling.” Grasscycling has several benefits:

- Save time by not bagging grass clippings.
- Save money by using fewer lawn bags.
- Add free nutrients to your grass, equal to one fertilizer application per year.
- Prevent your grass from drying out as quickly.
- Enjoy a healthier, greener lawn while saving time, money and resources.
- Does not promote thatch on your lawn.



Compost is “black gold”

Composting is a natural process that recycles plant materials. Over time, tiny micro-organisms break down dead and decaying grass, leaves, twigs and garden waste into a dark brown, organic soil amendment or mulch that is rich in nutrients.

Compost helps sandy soils (like those in the Anoka Sand Plain) hold moisture and nutrients that would otherwise drain through the soil, while adding it to clay soil improves its drainage and soil structure. Because it can improve your soil and help you grow healthier plants, many gardeners call it “black gold.”

Benefits of composting (indoors or outdoors) include:

- Reduce food waste from your garbage.
- Produce a valuable product to use on your lawn, around trees or in your garden.
- Convenient and easy to do.
- Save time hauling your leaves and grass clippings to the curb or a compost site.

Grasscycling - Send Your Grass Back to Its Roots

Leave your grass clippings on the lawn. Grasscycling can help you save time, money and natural resources while maintaining a healthy lawn. The nutrients in grass clippings equal one fertilizer application per year.

Six steps to a healthy lawn

The U.S. Environmental Protection Agency (EPA) outlines six preventive steps to a healthy lawn – a lawn that can overcome weeds, insects and disease. Grasscycling, when combined with these other simple measures, can lead to a healthy green lawn that is also good for the environment.

1. Develop healthy soil

Ensure success for your yard or garden by first having your soil analyzed for nutrients and organic material. Test your soil for:

- ✓ Texture (sandy, clay or in-between)
- ✓ pH (6.5-7.0 is ideal for grass)
- ✓ Nutrients (nitrogen, phosphorus, potassium)

To find out how to have your soil tested go to www.soiltest.cfans.umn.edu or a form can be picked up at the Bunker Hills Activity Center, 550 Bunker Lake Blvd NW, Andover, MN 55304, in the Anoka County University of Minnesota Extension office located in the lower level, 763-755-1280.

2. Choose the right type of grass

The appropriate grass variety grows well in the climate where you live, and is suited to the amount of sunlight, water, and nutrients your lawn receives. Appropriate varieties for Anoka County soils include Kentucky bluegrass and creeping red fescue combinations. The recommended percentages of each vary for a sunny versus a shady location.



3. Mow high, often and with sharp blades

Most lawns should be left at 2½" to 3½" high. This height helps the grass survive drought, weeds, insect damage and disease by growing thicker and developing a stronger root system. Mow your lawn frequently, and **never** cut more than one-third of the height of the grass blades. Leave the short clippings on the lawn to shade the roots and retain moisture. Use a sharp mower blade to prevent tearing the grass.

4. Water deeply and less frequently

To promote strong roots that help resist drought, it is healthier for the lawn to water deeply (5" into the soil) and less frequently, forcing the roots to grow deeper. If the soil is very dry, it may take ½" of water to wet a sandy soil down to a depth of 5". Water early in the morning to reduce loss by evaporation. Let the lawn dry out before watering again.

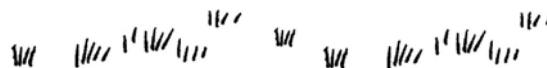

5. Correct thatch build-up

Thatch is the normal build-up of dead plant material between the living grass blades and the soil. Grasscycling does not promote excess thatch. Some grass varieties naturally form a thick layer of thatch. Excess thatch can also be caused by over-fertilizing. When the thatch layer builds up higher than ½", it can be reduced by raking or dethatching.

6. Set realistic goals

Even a healthy lawn will have some weeds or insect pests. It will also have insects and organisms that help keep pests under control. Save time, money and resources by setting realistic goals for the climate, soil type and location you have to work with. For example, wood chips or a shade garden may work better than grass at the base of a tree.

For more information visit www.extension.umn.edu, select Garden, Yard and Garden, Lawns and a list of resources will come up.

Take the "Waste" Out of Yard Waste

Grasscycling reduces the need for curbside collection of yard waste which can be costly because extra trucks and extra trips may be required.

Composting your grass clippings also reduces the energy and expense needed for curbside collection of yard waste. If you have too much grass to leave on your lawn (for example, if you are unable to mow it for several weeks); compost it.

Outdoor Composting

Outdoor composting is a great way to reuse your yard and fruit/vegetable waste. If you follow these easy directions, you'll turn those leaves, grass clippings and kitchen scraps into valuable compost.

Before you begin . . .

Check with your city or township to see if there are local ordinances regarding outdoor composting. Some communities require an enclosed container or a minimum set-back from your property line. Others specify what materials can be composted.

Think about your goal. Your compost pile will work even if you don't put much effort into it. It will simply take more time. However, if you want to have finished compost as soon as possible, your pile will require more time and effort.

Build or buy a bin

You can build your own compost bin, buy one at a local home improvement store or garden center, purchase a bin online or buy a bin through Anoka County. If you decide to build your own, consider how much yard waste you have when designing your bin. See pages 5 - 6 for more information.

Decide where to put your bin

- Convenient for you to add materials (next to your garden may be a good spot) and consider the distance from your kitchen to the bin
- Access to water
- Good drainage – place on bare ground
- Away from large trees – their roots steal nutrients and can grow into the compost
- Not against a building where compost can rot siding or other structural materials

Creating the right environment

Like a simple recipe, your compost pile needs the right mix of ingredients in order to produce the best results. Basically, you are managing the natural decomposition process by creating an environment for the microbes to function and break down the organic material you are adding to the pile.

A successful compost pile requires three things:

Air circulation

Microbes require air, otherwise the anaerobic (lack of free oxygen) microbes will take over, and they are stinky! On an established pile, air can be incorporated into the pile by turning the pile with a shovel, hoe or pitch fork, or by adding bulky, oddly shaped material to create air spaces in the pile.

Moisture

Natural bacteria, worms, fungi, and a variety of invertebrates help turn food and yard waste into compost. They need a moist environment to thrive. The microbes live in the thin sheath of water that coats the organic material in the compost pile. If there is no water, the microbes will dehydrate and die, but too much water will displace all of the air space causing anaerobic conditions. Overwatering can result in bad odor. In general, the mixture should feel about as damp as a wrung-out sponge.

The moisture test: Pick up a handful of the mixture and squeeze: if water drips out – that's too much. If the material falls to pieces as soon as you open your hand – that's too dry. If the mixture stays in a clump for a few seconds before breaking apart – that's just right.

The right ingredients

You need to add two kinds of materials: some that are rich in nitrogen and some that are rich in carbon. The microbes that convert your waste into compost need both nitrogen and carbon sources to thrive. Carbon sources are typically brown or yellow, such as leaves, straw, hay and sawdust. These materials tend to be dry as well. Good nitrogen sources usually contain a lot of moisture, and are green and succulent, such as grass clippings, green prunings, and fruit/vegetable scraps.

As a general rule, add three parts of dry ingredients (carbon sources) – leaves or dry grass – to one part of wet food waste or fresh grass (nitrogen sources). Always mix some brown/dry materials with your grass clippings to prevent odor.

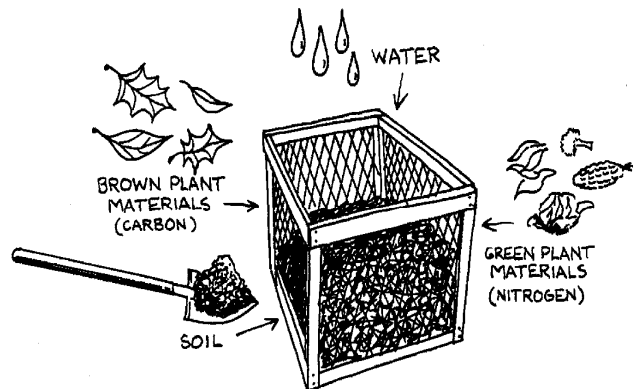

What Can Be Composted Outdoors?

- ✓ Acorns
- ✓ Coffee grounds & filters
- ✓ Corn husks
- ✓ Egg shells (rinsed)
- ✓ Fruit/vegetable scraps, rinds & peels
- ✓ Garden residue (no diseased plants)
- ✓ Grass clippings
- ✓ Hay
- ✓ Leaves
- ✓ Nut shells
- ✓ Pine needles
- ✓ Plant trimmings
- ✓ Sawdust
- ✓ Shredded paper
- ✓ Straw
- ✓ Tea bags & leaves
- ✓ Twigs



Don't add meat or dairy products

Kitchen scraps, such as fruit and vegetable peelings, bread (without butter), coffee grounds, and rinsed egg shells can be added to your compost pile. However, do not add meat or dairy products as they will turn rancid and smell, attracting rodents and pests. Also, do not put pet waste in your compost bin as it may harbor disease pathogens that are dangerous to humans and will cause odor as well.

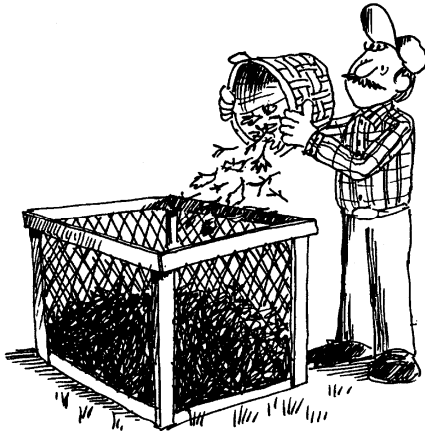

Stir the compost pile

Every few weeks, turn the pile with a shovel or pitchfork to add air. Microbes will work harder and organic material will break down faster if the pile is turned one or two times a month. If you don't turn it composting will still occur, just not as quickly.

Maintain your compost pile

Add yard waste and food scraps as they become available. Cover fruit/vegetable scraps with a thin layer of yard waste or soil to keep flies away. Remember to water and turn the pile occasionally.

When is the compost ready?

Compost is finished when it is dark brown, crumbly, and earthy smelling. If you start composting in the spring, it may take until the following spring to have finished compost. See page 9 for ideas on what to do with your finished compost.

For more technical information about backyard composting, visit www.extension.umn.edu/distribution/horticulture/DG3296.html

Tip for Better Composting

- ✦ Don't add diseased plants or weeds with runners or mature seeds unless you plan to monitor the temperature carefully. The pile must stay at 130-160°F for a few days to kill any disease or weed seeds, which is hard (if not impossible) to do in a small compost pile. Otherwise, you risk spreading the disease and/or weeds when you use the compost.

Outdoor Compost Troubleshooting (Problems, Causes and Solutions)

Problems	Causes	Solutions
Odor	Not enough air, or too much grass.	Turn the pile; add dry material if pile is too wet; add brown material if pile contains too much grass.
Odor and/or pests and rodents in the pile	Meat, fat or dairy products in pile.	Remove and discard meat/dairy products.
Center of the pile is dry	Not enough water.	Moisten and turn the pile.
Pile is damp and warm only in the middle	Compost pile is too small.	Add more materials; mix the old and new materials together.
Pile will not heat up	Lack of nitrogen in the pile.	Mix in a nitrogen source: fresh grass clippings, or fertilizer.

Building Your Own Compost Bins

Outdoor Structures

Anoka County has been buying large quantities of compost bins and are therefore able to sell them at a reduced fee. Call 763-323-5730 or visit www.AnokaCounty.us/yardwaste for more information. Some cities require that composting be done in an enclosed container. Check with your city or town hall to determine the requirements. If you plan to compost lots of food waste outdoors, you may want to consider purchasing an enclosed compost bin with a lid. The Web site www.composters.com provides many options that are commercially available. Another option is to build your own. Many types of outdoor bins can be constructed at home and styles vary. The round bin is easy to assemble, but if you have more material to compost, you may want to consider building the three-bin compost system. Following are instructions for two compost bins.

Three-Bin Compost System

Materials and Equipment:

- ✓ Three 9' 2x4s (bottom and top braces)
- ✓ Five 12' 2x4s (dividers and grooved strips)
- ✓ Eighteen 3' 1x6s (front slats)
- ✓ Twelve 4" carriage bolts
- ✓ Five pounds galvanized nails (16d)
- ✓ 21' 2"x 2" wire fencing (36" width)
- ✓ Heavy-duty stapler
- ✓ Drill
- ✓ Table saw
- ✓ Hammer
- ✓ Wire cutters

Construction:

- Place the bottom braces on a flat section of ground. Put two 9' 2x4s 33" apart.
- Cut four of the 12' 2x4s into four pieces. Two of the pieces should be 32" long to form the sides of the dividers. The other two pieces should be 36" long, for the top and bottom of each divider. Nail the four pieces into a 32"x 36" square. You will have four squares this size.

- Staple a 3' square of wire fencing to one side of each divider. Drill and bolt the dividers to the bottom braces (see illustration) making sure that the wire on the end dividers faces outward.
- Brace the back of the composter with a 9' 2x4 across the top of the dividers.
- Cut a 9' length of wire fencing and fasten it to the back of the composter with staples.
- The front end of each bin is closed off as the bins are filled. Use six 1x6 boards for each bin. Drive a nail halfway into the long edge of each slat to create a ventilation space between slats when slid into place.
- The boards slide into position along grooved strips nailed to the front of each divider. The two outside strips are L-shaped, and the inside strips are T-shaped; both can be cut on a table saw from a 12' 2x4 (see illustration).

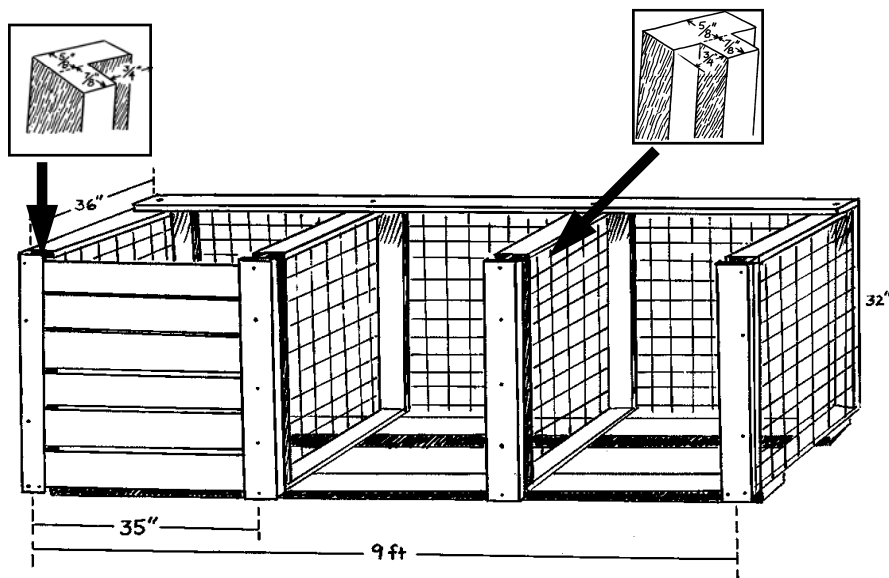

Using a Three-Bin System

Collect leaves, garden waste and food scraps in the first bin. Follow the directions in this booklet for composting, turning often. When the pile has reduced in size by about one-third, turn the entire pile into the middle bin and place a fresh batch of yard waste into the first bin. When the middle pile turns into a brown, crumbly material, move it to the last bin for final curing and storage until needed. Piles should sit and cure for about a month after the materials have totally broken down.

Round Bin

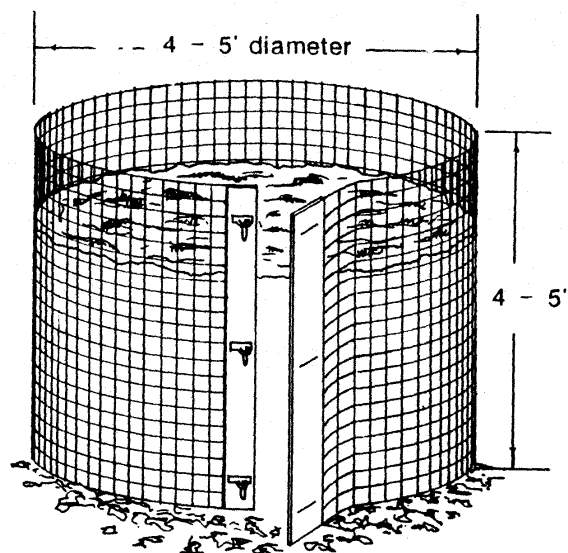

Materials and Equipment:

- ✓ Small-spaced woven wire, 19' long and 4-5' high.
- ✓ Chain snaps or wire pieces to hold ends together.

Construction:

- Pull the two ends of the wire together to form a circle that is 4-5' across. Connect the two ends with chain snaps or by fastening them with small pieces of wire.
- The easiest way to turn the compost in this structure is to unsnap the wire, move the cylinder over a few feet, and turn the compost back into it.

Indoor Worm Bin Structures

Indoor bins are easy to design. You can create a larger bin by increasing the size of the bottom and side boards. For example, a good size for 4-5 people is a 3' x 2' bin.

Using a Plastic Tub as a Worm Bin

A large plastic storage box or tub is perfect for a worm bin. You can find them at home improvement or general merchandise stores. Find an appropriate size bin, drill or punch holes in the bottom, and add your bedding. You can use the existing lid or make one from black plastic film. Make sure there is enough ventilation so the box doesn't get too wet.

2 x 2 Worm Box (2-Person Box)

Materials and Equipment:

- ✓ 4 pieces 5/8" CDX plywood (23³/₈" x 8")
- ✓ 1 piece 5/8" CDX plywood (24" x 24")
- ✓ 4 pieces of wood (2" x 2" x 2")
- ✓ 36 2" galvanized nails
- ✓ Drill with 1/2" bit
- ✓ Black plastic sheet (24" x 24")
- ✓ Hammer
- ✓ Newspapers or an old baking sheet

Construction:

- Nail the four sides (23³/₈" x 8") together; overlap each corner, then nail the bottom to the frame created by the sides.
- Drill 8-10 holes in the bottom for aeration and drainage.
- Use the black plastic sheet for the cover or another piece of plywood.
- Nail four 2" x 2" x 2" feet to the bottom corners of the box so it is elevated.
- Place newspapers or baking tray under the box to catch any drainage.
- To make harvesting the compost easier, a mesh screen, such as hardware cloth, may be used to divide the bin in half; large enough to allow the worms to cross over to fresh food and bedding but small enough to prevent new food scraps from mixing in with the finished compost.

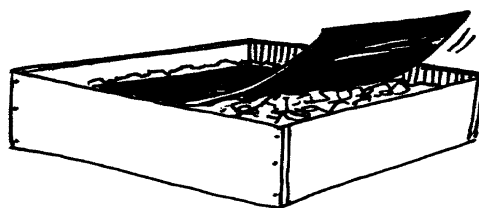

The following two pages explain in further detail how to compost with worms.

Indoor Composting

Worm composting indoors is a little more work than outdoor composting, but with worms you can compost during the cold winters. Redworms are the most desired species for composting because they are avid garbage eaters and they reproduce quickly. One pound of worms can eat 200 pounds of garbage a year. Redworms are also known as red wigglers, manure worms or red hybrids – their scientific name is *Eisenia foetida*. The redworms and microbes work together to compost your food waste.

Make or purchase a worm box

Worm composting boxes are commonly wood or dark-colored plastic boxes with lids. They provide a dark and moist environment for the worms. Plastic boxes do not dry out as easily as wooden boxes, however, they have a tendency to stay too wet and may need holes added for ventilation. With both systems, you must ensure the worms neither drown nor dry out. See previous page for a worm box design.

Decide where to put your worms

The worm box needs a location that maintains a 55-75°F temperature. This is the best environment for the worms to convert food waste to compost.

Prepare the bedding

Bedding is a major component of the worm composting system. It must hold moisture while remaining light and fluffy to give the worms plenty of air. The bedding should not be toxic because the worms will eventually eat the bedding as well as the garbage. Good bedding includes paper towels, corrugated cardboard or newspapers. Do not use colored newspaper inserts or magazines. Shred all bedding into 1" wide strips. You will need approximately 4-6 pounds (dry weight) of bedding for a 1' x 2' x 2' box or 9-14 pounds for a 1' x 2' x 3' box.

Water is also very important for the worms' survival. A worm's body is 75-90% water, and it must be moist for the worm to breathe. Dip the bedding into a bucket of water for a few seconds, shake it off and add it to the bin. Throw in a couple handfuls of soil to provide grit, which helps the worms digest food.

Figure out how many worms you need

To determine how many worms to buy, you need to know how much food waste you produce in your home. The garbage to worm ratio is 1:2. For example, if you generate about 1 pound of compostable food scraps each day, you will need 2 pounds of worms. See the Resources section on the back cover for a list of redworm distributors.

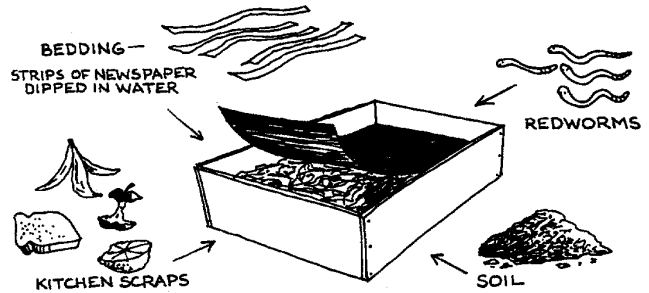

Add worms

It's time to add the redworms to the box. Dump them directly onto the prepared bedding. Spread the worms out on the surface and leave the lid open. Redworms do not like light, so they will begin to move down into the bedding. After one hour, most of the worms should be out of sight. Remove those still on the surface of the bedding, since they are likely to be dead or unhealthy.

Add food scraps

Add food scraps slowly at first since your worms are immature and need time to reach maturity and reproduce. Then add vegetative food scraps to your worm box as you generate them. **Avoid meat scraps and dairy products, which will smell.** Cover the new waste with an inch or so of the existing bedding and close the lid. That's all there is to it. Put the food waste in a new section of the box each week. Once every two weeks, dig into the box and check on the worms' progress. Fluff up the contents of the box and add more bedding as things decompose and start to compact. To avoid odors, you must provide a good air supply in the box.

Food Waste You Can Compost Indoors:

- ✓ Baked beans
- ✓ Bread
- ✓ Cake
- ✓ Coffee grounds
- ✓ Cooked cereal
- ✓ Dry cereal
- ✓ Egg shells (rinsed)
- ✓ Fruit scraps
- ✓ Molasses
- ✓ Noodles
- ✓ Pancakes/waffles
- ✓ Tea bags
- ✓ Vegetable scraps



How to harvest the compost

After 2-3 months, the compost will be ready to harvest. If you have added fresh food scraps or bedding within the past three months, traces of it may be left in the compost. Return this material to the box after the compost has been removed. There are three easy ways to harvest.

Worm Sorting:

1. Pile all of the compost and worms on one side of your compost bin.
2. Place fresh bedding in the vacant half of the worm box.
3. Place fresh food scraps into the new bedding so the worms will move into this section of the box.
4. In a few weeks, all of the worms will have moved into the new bedding. You can remove the finished compost, fill the space with fresh bedding and continue the process.

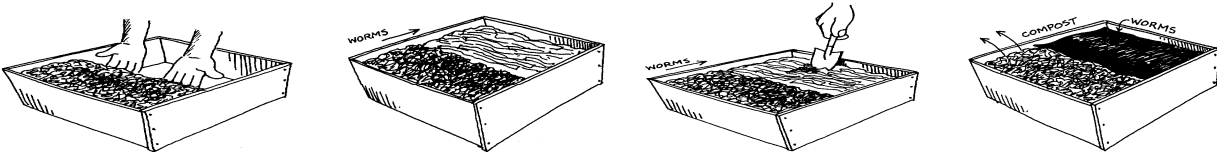

Simple Separation: Remove $\frac{2}{3}$ of the compost (worms and all) and dump it into the garden (or wherever you plan to use your compost outside). The remaining $\frac{1}{3}$ compost and worms are usually enough to repopulate the system. Add fresh bedding and continue the process.

Hand Sorting: Dump the contents of your worm box onto a large plastic sheet. Do this outside or have an overhead lamp near your work area. As the worms move into the pile to escape the light, remove the top and sides of your pile. Continue removing the top and sides until there is nothing but a small mass of compost and worms left in the pile. Replace the bedding in your bin and place the worms back in to restart the process.

Indoor Compost Troubleshooting (Problems, Causes and Solutions)

Problems	Causes	Solutions
Odor	Scraps not covered by bedding. Too wet. Lack of air in bedding. Too much food waste in box.	Mix in scraps; keep them covered. Add more bedding. Fluff up bedding; leave lid off. Decrease scraps; try larger box or more
Fruit flies	Fruit flies often enter the house on bananas and lay their eggs in the worm box.	Put the box outside in cold weather for 3-4 hours. This will kill the flies but not the worms. You can also vacuum them up or try a
Excess water in box	Bedding is too moist. Either too much water was put in with bedding or very moist food was put in box.	Remove water with a baster (you can feed it to your house plants). Mix more dry, clean bedding with the old bedding.
Worms dying or escaping	Too wet. Too dry. Too acidic.	Add more bedding. Moisten bedding. Cut down on citrus peels.

* Fruit fly trap: Pour one-half cup of beer into a jar. Place a plastic bag over the mouth of the jar and secure it with a rubber band. Poke a $\frac{1}{4}$ " hole into the corner of the bag that reaches down into the jar. Place the jar on top of the bedding in your worm box. The flies will be attracted to the beer and will find their way into the jar, but will not be able to find their way out.

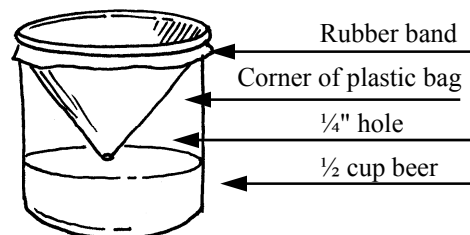

Using Your Finished Compost

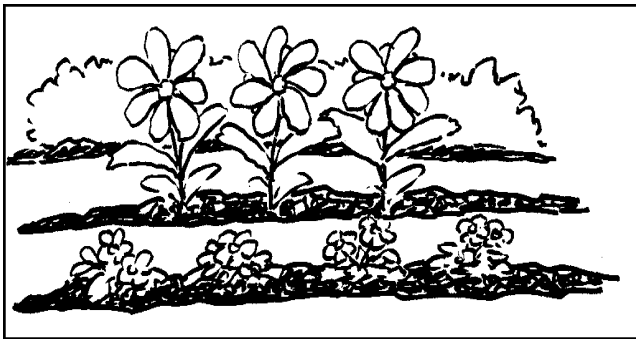

The addition of organic matter such as compost benefits all types of soil in several ways. Compost improves soil structure, which is usually damaged in urban sites due to construction. Compost breaks up clay soils, increasing the amount of air spaces. This allows more oxygen into the soil for plant roots and improves water drainage. Coarse, sandy soils dry out very quickly because of their rapid drainage. Compost increases the ability of the soil to hold moisture and nutrients which improves drought tolerance of plants. Compost also incorporates and promotes the growth of beneficial microorganisms which are necessary for plant growth and health.

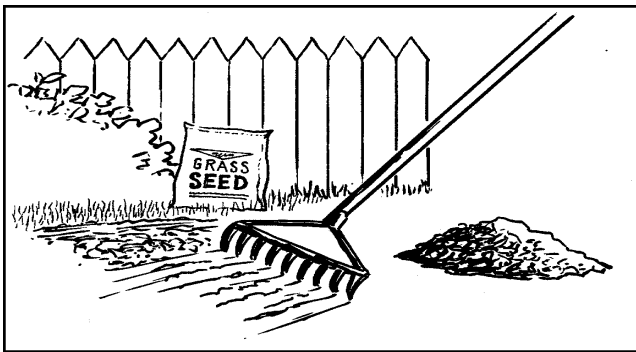

Gardens

In a vegetable or flower garden, shovel 3"- 6" of compost on top of the garden area before working it into the soil at a depth of 10"- 12". It is beneficial each year to work in 3"- 4" of compost into the soil. For established areas, spread the compost evenly between plants and carefully work it into the soil as much as possible. Material that is left on top works well as mulch. Worms will also help to mix additional material into the soil. Piling it around the base of the plants after they're up and growing will help them retain moisture and can deter weed growth.

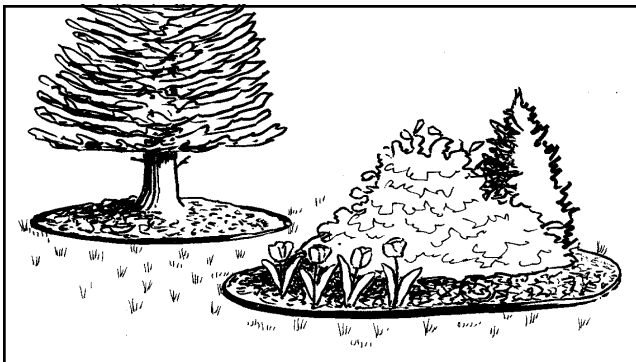

Lawns

Before planting a new lawn, work in a lot of compost to a depth of 6" to provide a nutrient-rich mixture for the grass roots. To renovate an old patchy lawn, dig up the bare spots about 2" deep. Work in plenty of finished compost, tamp and rake. Sow your grass seed after soaking the patches well.

Trees and shrubs

Top dress the soil around your trees and shrubs with compost. Work it into the soil surface one foot from the trunk out to one foot beyond the drip line. For new plants, apply a 4" depth of mulch from near the trunk (do not touch the trunk) to 12" beyond the rootball. Enlarge the radius as the plant grows to assist the tree or shrub in establishing its root system.



House plants and outdoor pots

Compost can also be used when potting plants. A good potting mixture is composed of equal parts loam or peat, sand and compost. If you want a finer mix, put the compost through a 1/4" mesh screen before you add it to the mixture.

Anoka County Compost Sites

Anoka County has two yard waste drop-off sites available to its residents: Bunker Hills Compost Site in Coon Rapids, and Rice Creek Chain of Lakes Compost Site in Lino Lakes. The sites provide a good option when you have large quantities of leaves or grass clippings that you are unable to compost or leave on your lawn at home. You must show proof of residency to use these sites. Residents may also take finished compost from the sites when it is available. Remember to bring your own shovel and containers. Keep leaves and grass separate from tree waste since the fees are assessed separately.

Leaves and Grass (and other non-woody materials)

There is a vehicle user fee to use the sites. All yard waste must be debagged. Please unload your yard waste and take your bags and containers home with you.

Tree Waste

Brush, evergreen boughs, logs and stumps are charged by the cubic yard depending on the size and amount of the material. Tree waste may be loose or bundled. The more compact you make your load, the lower the fee.

For more information call Anoka County Integrated Waste Management at 763-323-5730 or visit www.AnokaCounty.us/recycle

Yard Waste Accepted

- ✦ Grass Clippings
- ✦ Leaves
- ✦ Soft Bodied Green Plants
- ✦ Garden Waste
- ✦ Pine Cones and Needles
- ✦ Sod (residential quantities)
- ✦ Weeds
- ✦ Acorns
- ✦ Brush
- ✦ Logs
- ✦ Stumps



Compost Site Hours

April through November (weather permitting)
Sites close at times indicated or **at sunset, if earlier**

Coon Rapids/Bunker Hills Site 763-767-7964

Mon. through Fri: 10 a.m. to 7 p.m.
Saturday: 9 a.m. to 5 p.m.
Sunday: 12 p.m. to 5 p.m.

Lino Lakes/Rice Creek Site 651-429-3723

Tues. and Thurs: 10 a.m. to 7 p.m.
Saturday: 9 a.m. to 5 p.m.
Sunday: 12 p.m. to 5 p.m.

Sites are closed on the following holidays: Easter Sunday, Memorial Day, Independence Day, Labor Day, Thanksgiving Day

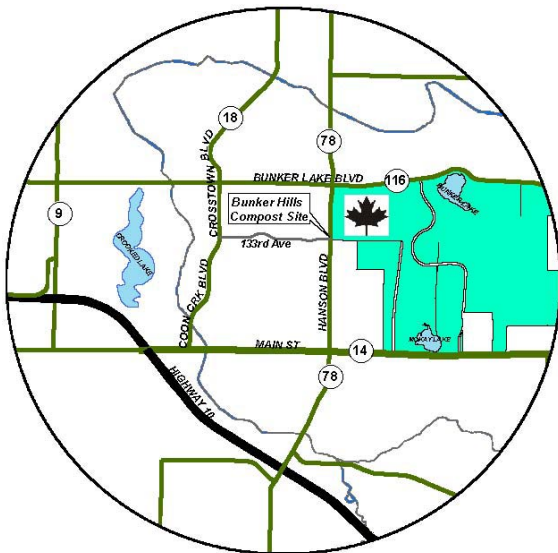

Bunker Hills Compost Site
13285 Hanson Blvd, Coon Rapids
One mile north of CSAH 14 (Main St.)

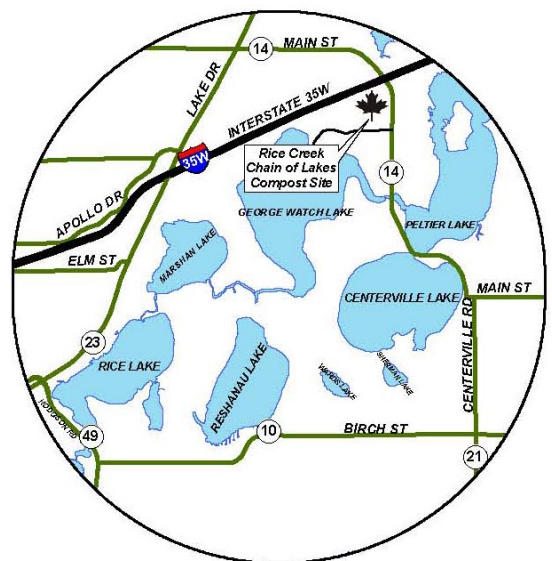

Rice Creek Chain of Lakes Compost Site
7701 Main St, Lino Lakes
Note: there is no exit onto CSAH 14 from 35W

Resources and References

Worm Suppliers for Indoor Composting:

Recycling Association of Minnesota (RAM) 651-641-4560
Search for “red worms” on the internet. You can access the Internet at all Anoka County libraries.

Where to Look for More Information:

University of Minnesota Extension in Anoka County 763-755-1280
The University of Minnesota Extension provides excellent information on lawn care, backyard composting and indoor vermicomposting. Residents can order several different publications online or information is also available at www.extension.umn.edu. Click on the Garden tab and self-search by topic. Master Gardeners in Anoka County are also available to assist with questions regarding these and other lawn and garden topics.

U. S. Environmental Protection Agency (EPA) 1-800-490-9198
“Healthy Lawn, Healthy Environment: Caring for Your Lawn in an Environmentally Friendly Way” contains information on integrated pest management, pesticides, and how to choose a lawn care service. Visit www.epa.gov/oppfead1/Publications/lawncare.pdf

Your Local Library

There are many good books on composting, grasscycling and lawn care. *The Rodale Book of Composting* (Deborah Martin and Grace Gershuny), *Backyard Composting: Your Complete Guide to Recycling Yard Clippings* (Harmonious Technologies) and *Worms Eat My Garbage* (Mary Appelhof) are good references.

The Internet

Composting information abounds on the Internet. You can find information by searching for “composting,” “grasscycling,” “vermicomposting,” and other key words. You can access the Internet at all Anoka County libraries.

Acknowledgments

This guide was initially adapted from a publication produced by the Western Lake Superior Sanitary District (WLSSD). Special thanks to WLSSD for use of their information and graphics. Additional technical information was provided by the University of Minnesota Extension resources.

Printed on 100% post-consumer recycled paper, using agri-based ink.



Anoka County Government Center
Integrated Waste Management
2100 3rd Avenue, STE 340
Anoka, MN 55303-5032
763-323-5730
recycle@co.anoka.mn.us
www.AnokaCounty.us/recycle

Information provided by the Anoka County Board of Commissioners.